



# On-Premises Softmount Washer-Extractors

## SY350, SY450, SY600

### Features

- Freestanding, high spin
- Stainless steel cabinet
- Stainless steel drum and tub
- QED Select – fully programmable microprocessor
- Large door opening (Ø 54 cm) for easy loading and unloading
- Large drain valves (2 × Ø 76 mm)
- Easy access to all parts
- Frequency controlled motor
- Perforated lifting ribs: more mechanical action and lower water consumption
- Eco washing programs – significantly reduces water and electricity consumption
- Soap hopper
- Liquid soap print
- USB & RS485 plug (on the back panel)

### Options

- Liquid soap pumps
- QED Assist – Laundry management software
- End of cycle light and sound signalization
- Forward tilting device (pneumatic) for SY450 and SY600
- Automatic weighing system by weighing cells for measuring exact capacity of the linen
- Air operated water inlets
- Tap to take water samples
- Soap dispenser with 5 removable compartments
- Isolation for energy & noise reduction



Control panel (QED Select)



Easy Operation



Ergonomical Construction



Robust Design



Large Door Opening

# On-Premises Softmount Washer-Extractors

## Specifications

	SY350	SY450	SY600
<b>INNER DRUM CAPACITY</b>			
Volume [l]	350	450	600
Volume [kg]	35	45	60
Depth [mm]	535	690	715
Diameter [mm]	914	914	1035
<b>MOTOR</b>			
Power [kW]	4	7.5	7.5
<b>DRUM SPEED</b>			
Wash speed (default) [rpm]	45	45	42
Extraction speed (default) [rpm]	839	839	788
G-factor	360	360	360
<b>PROGRAMMER</b>			
Type of control	QED Select	QED Select	QED Select
<b>CABINET</b>			
Stainless steel	Yes	Yes	Yes
Door Opening [mm]	540	540	540
Door Opening angle [mm]	178	178	178
<b>HEATING</b>			
100% Hot Water [°C]	90	90	90
100% Electrical [kW]	24	36	54
Steam High Pressure [bar]	3 – 8	3 – 8	3 – 8
<b>CONNECTION</b>			
Water Inlet [in]	3 × 1"	3 × 1"	3 × 1"
Steam Inlet [in]	1 × ¾"	1 × ¾"	1 × ¾"
Drain Diameter [in]	2 × 3"	2 × 3"	2 × 3"
Drain valve outer [mm]	2 × 76	2 × 76	2 × 76
Flow amount with drain valve [l/min]	2 × 210	2 × 210	2 × 210
<b>POWER</b>			
Electrical requirements [V/Hz]	3×200–240V/50–60Hz 3×380–415V/50–60Hz 3×440–480V/50–60Hz	3×200–240V/50–60Hz 3×380–415V/50–60Hz 3×440–480V/50–60Hz	3×200–240V/50–60Hz 3×380–415V/50–60Hz 3×440–480V/50–60Hz
Heating element [kW]	24	36	54
<b>TILTING</b>			
Forward tilting	n/a	Option	Option
<b>TRANSPORT DATA</b>			
Net Weight [kg]	1010	1350	1500
Net Weight (w/tilting) [kg]	n/a	1390	1540
Shipping Weight [kg]	1170	1490	1640
Shipping Weight (w/tilting) [kg]	n/a	1530	1680
Crate packing volume [m³]	4.45	5.15	5.15
Crate packing volume (w/ tilting) [m³]	n/a	5.26	5.26
<b>DIMENSIONS</b>			
Dimensions H×W×D [mm]	1925×1315×1270	1925×1315×1502	1925×1315×1502
Packaging dimension H×W×D [mm]	2125×1425×1470	2125×1425×1700	2125×1425×1700

# On-Premises Softmount Washer-Extractors

## Dimensions

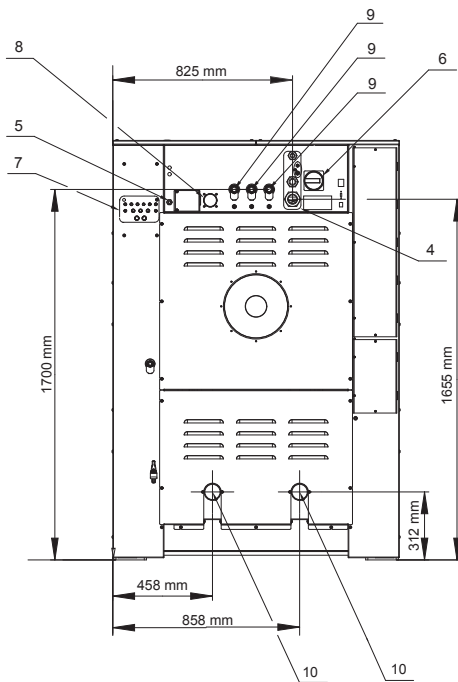
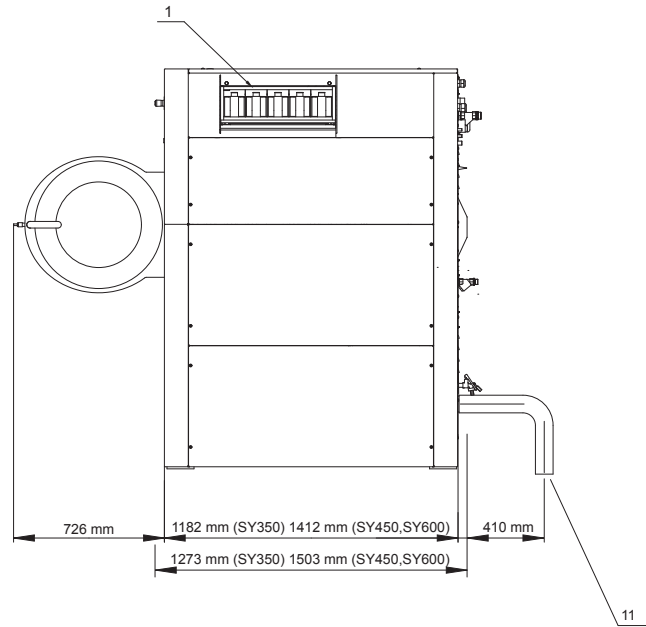
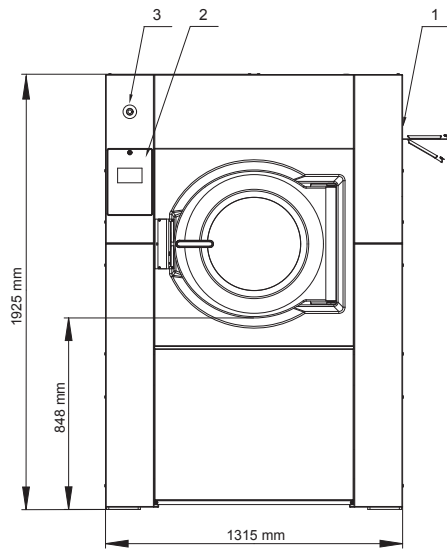

- 1 Soap hopper
- 2 Keyboard
- 3 Emergency stop
- 4 Electrical connection
- 5 Electrical connection t liquid soap
- 6 Main switch
- 7 Liquid soap pump connections
- 8 Air vent tub
- 9 Water connection
- 10 Drain valve
- 11 Water sample tap