



Speed Queen Commercial Stack Washer and Dryer

STLWXASP303NN22

A proven performer

Get the complete package in a single unit, combining our efficient dryers with the powerful performance of our industry-leading front load washers. Available in 9.5 kg (21.5 lb) washer capacity and 8.2 kg (18 lb) dryer capacity. Our line of stack washer/dryers are designed as vertical combinations that provide all the power of Speed Queen washers and dryers while occupying only half of the floor space of a conventional washer and dryer setup. Plus, these stacked units allow you to utilize the same connections and hook-ups required by a standard washer and dryer and come preassembled for simple installation.



Built better to last longer

The Vend front load washer offers a hygienic rinse cycle, minimising maintenance and delighting customers. This provision was ranked as the number one laundromat requirement in our consumer survey. Speed Queen dryers are uniquely quiet making them ideal for use in any densely populated areas. Additionally for convenience and to help with the efficient provision of a superior service, they feature an extended tumble that helps eliminate wrinkling by tumbling for two minutes at 20 minute intervals if the door isn't opened.

Quantum Gold

This control enables networking with our larger equipment and off-site management. Quantum™ Gold also offers owner and customer benefits such as PC programming and machine audit capabilities, time-of-day pricing, 'lucky cycles', cycle modifier keys and much more.



Specifications

Speed Queen Commercial Stack Washer and Dryer

Model	STLWXASP303NN22
General details	
Control	Quantum
Control location	Front 10 degree
Actuation	Prep for coin
Drum	
Capacity kg	15 (W) / 15 (D)
Volume l	W-96,8/D-198
Drum speed	
G-factor	440
Extraction RPM	1200
Power	
Motor power kW	W-0,67/D-0,25
Voltage	220-240/50/1 (W) 220-240/50/1 (D)
Cabinet	
Cylinder Finish	Stainless / Stainless
Color	Stainless
Door type	W-Window / D-Solid
Connections	
Electrical requirements	220-240/50/1 (W) 220-240/50/1 (D)
Gas inlet connection mm	9,525
Water inlet	3/4"
Water Pressure kPa	1,4-8,3
Transport data	
Net weight kg	175
Shipping weight kg	189
Dimensions HxWxD mm	1986 x 683 x 711
Packed dimensions HxWxD mm	2032 x 762 x 864
Packed volume m3	1,34

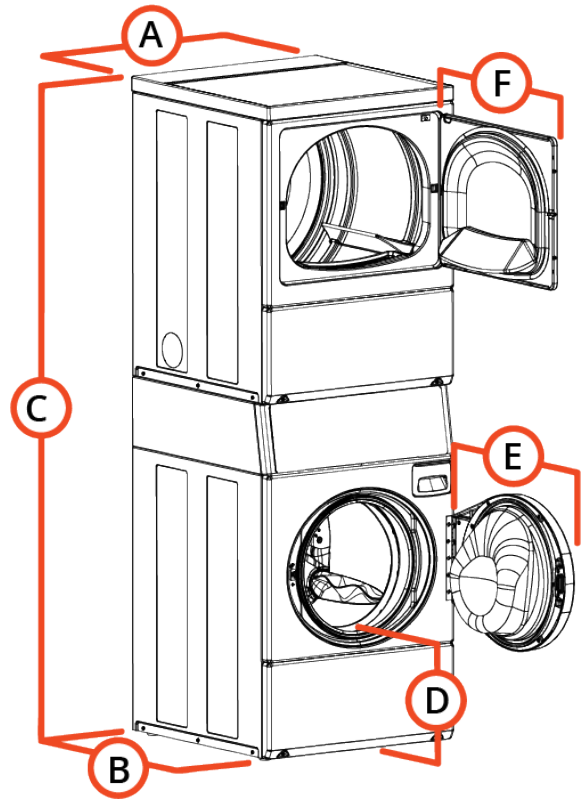

Dimensions

	mm
A	683
B	711
C	1986
D	371
E	610
F	597