



# On-Premises Softmount Washer-Extractors

## SY65, SY80, SY105, SY135

### Features

- Freestanding, high spin (up to 1165 RPM – SY65, SY80)
- Stainless steel top front panel, side panels
- Stainless steel drum and tub
- QED Select – fully programmable
- Patented soap hopper
- Large drain valve (Ø 76 mm)
- Easy access to all vital parts from the front
- Large door opening for easy loading and unloading
- Perforated lifting ribs: more mechanical action and lower water consumption
- Eco washing programs – significantly reduces water and electricity consumption

### Options

- Coin operated
- USB plug and Network cable connection (on the back panel)
- Liquid soap connection
- Liquid soap pumps
- Water recovery kit
- Steam heating version
- Drain pump (SY65, SY80)
- 3rd water inlet
- QED Assist – Laundry management software



Control panel (QED Select)



Easy Operation



Ergonomical Construction



Large Door Opening



Low Water Consumption

# On-Premises Softmount Washer-Extractors

## Specifications

	SY65	SY80	SY105	SY135
<b>INNERDRUM</b>				
Maximum capacity 1:10 [kg/lb]	6.5/14	7.5/20	10.5/25	13.5/30
Volume [l]	65	75	105	135
Diameter [mm]	530	530	620	620
<b>DRUM SPEED</b>				
Wash [rpm]	49	49	49	49
Extraction [rpm]	1165	1165	1075	1075
G-factor	400	400	400	400
<b>HEATING</b>				
Electricity (standard) [kW]	3/4.6/6/9	3/4.6/6/9	3/4.6/6/9/12	4.6/9/12
Steam [bar]	1 – 8	1 – 8	1 – 8	1 – 8
Hot water [°C]	90	90	90	90
Sound pressure level [dB (A)]	<65	<65	<65	<65
Water valves connection [BSP]	¾"	¾"	¾"	¾"
Water pressure [kPa]	100 – 800	100 – 800	100 – 800	100 – 800
Rec. water pressure [kPa]	300 – 500	300 – 500	300 – 500	300 – 500
Water inlet [l/min]	20	20	20	20
Drain valve [outer Ø mm]	76	76	76	76
Flow amount with drain valve [l/min]	210	210	210	210
Steam valve connection [BSP]	½"	½"	½"	½"
Steam pressure [kPa]	100 – 800	100 – 800	100 – 800	100 – 800
<b>DIMENSIONS</b>				
Size HxWxD [mm]	1115x710x740	1115x710x790	1225x795x795	1225x795x945
<b>TRANSPORT DATA</b>				
Gross Weight [kg]	180	200	235	275
Net Weight [kg]	170	185	210	255
Packaging Dimension HxWxD [mm]	1245x750x840	1245x750x840	1345x835x840	1345x835x985

# On-Premises Softmount Washer-Extractors

## Dimensions

	A	B	C	D	E	F	G	H	I	J	K	L	M	N	O	P	Q	R	S
SY65	710	646	1115	740	349	230	82	914	1004	113	218	293	390	1020	24	1019	480	42	180
SY80	710	696	1115	790	349	230	88	920	1010	113	218	293	390	1020	24	1025	480	42	180
SY105	795	696	1225	795	342	230	88	1030	1120	113	218	293	475	1130	24	1135	506	42	180
SY135	795	846	1225	945	342	230	88	1030	1120	113	218	293	475	1130	24	1135	506	42	180

	T	U	V	W
SY65	203	-	67	48
SY80	203	-	67	48
SY105	203	274	67	48
SY135	203	274	67	48

All measurements are in mm.

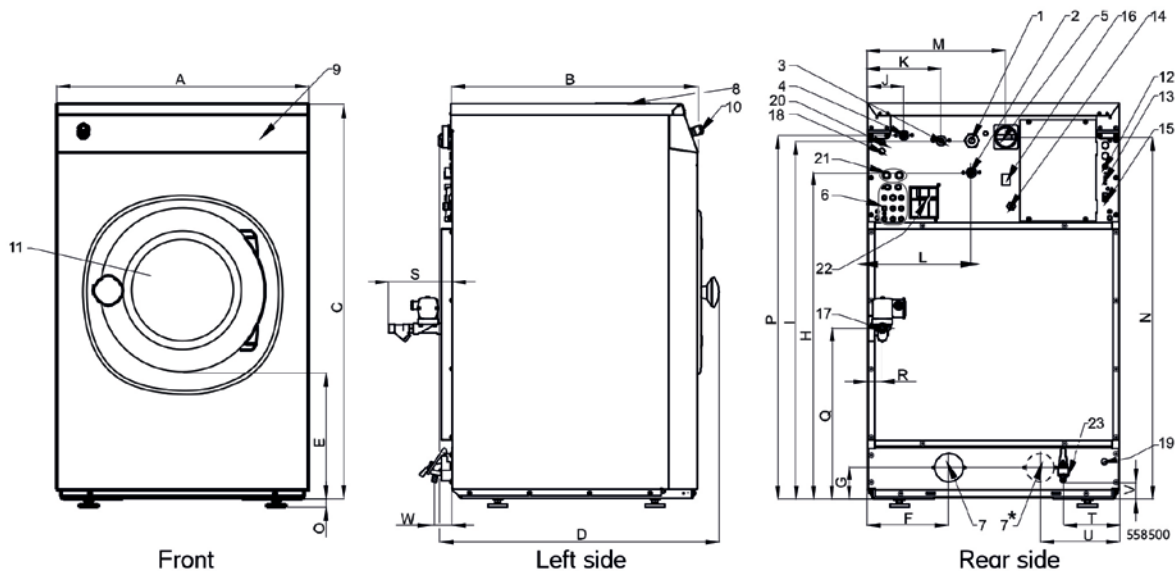

- |    |   |    |  |
|----|---|----|--|
| 1  | Electrical connection   | 13 | USB port   |
| 2  | Hot water   | 14 | Electrical connection to liquid soap pumps   |
| 3  | Cold water hard   | 15 | PC programming connection (RS485)  |
| 4  | Cold water soft   | 16 | Heating change-over switch (electrical heating, steam heating)                       |
| 5  | Main switch   | 17 | Steam connection (steam version) ½++   |
| 6  | Connection liquid soap  | 18 | Steam valve connection (steam version)   |
| 7  | Drain: drain valve (pump), 1 ×ø76 mm<br>SY280 – drain valve or recycle valve,<br>1 ×ø76 mm (on request) | 19 | Inlet of cable for discharge of water into the water recycle                         |
| 8  | Soap dispenser  | 20 | Cable inlet – cable for control of the valve or pump of water from the water recycle |
| 9  | Control panel   | 21 | Inlet of water from the recycle (external diameter 19)                               |
| 10 | Button CENTRAL STOP   | 22 | Air relieve  |
| 11 | Door opening:<br>SY65 and SY80 – ø330<br>SY105 and SY135 – ø410   | 23 | Drain valve ½", applicable for wash bath sample (on request)                         |
| 12 | Fuses   |    |  |