



Speed Queen Home Retail Dryer

ADEE9RGS565XW01

A proven performer

Speed Queen® dryers are designed, tested and built to deliver 25 years of commercial-grade performance in your home. Featuring customizable drying cycles, sophisticated airflow patterns, and advanced moisture sensing to deliver consistently superior results and efficiency. So you can reduce your dry times, eliminate unnecessary drying, lower your utility bills and protect your clothes.

Perected drying

Through special drying cycles, a flawless Axial Airflow pattern and advanced moisture sensing, you can eliminate excessive drying and save money on your utility bill. If you want durability, innovation and perfectly dried laundry the first time, you need a Speed Queen dryer.



Specifications

Speed Queen Home Retail Dryer

| | |
|----------------------------|------------------------|
| Model | ADEE9RGS565XW01 |
| Gas Heating | |
| GasInlet Mm | N/A |
| General details | |
| Control | HEC |
| Control location | Rear |
| Actuation | None |
| Drum | |
| Capacity kg | 10,5 |
| Volume l | 198 |
| Motor | |
| Motor power kW | 0,25 |
| Cabinet | |
| Cylinder Finish | Galvanized |
| Color | White |
| Door type | Solid |
| Connections | |
| Electrical requirements | 230/50/1 |
| Gas inlet connection mm | N/A |
| Water inlet | N/A |
| Water Pressure kPa | N/A |
| Transport data | |
| Net weight kg | 57 |
| Shipping weight kg | 62 |
| Dimensions HxWxD mm | 1086 x 683 x 711 |
| Packed dimensions HxWxD mm | 1156 x 775 x 826 |
| Packed volume m3 | 0,74 |

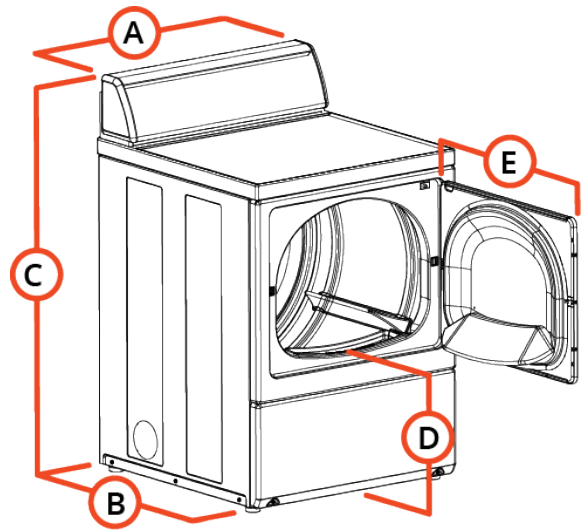

Dimensions

| | mm |
|---|------|
| A | 683 |
| B | 711 |
| C | 1086 |
| D | 392 |
| E | 597 |